

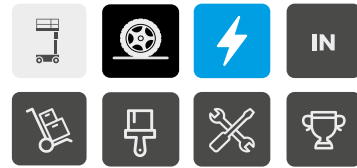

STAR 8 S



GO EVERYWHERE...

- > High precision driving and smoothness
- > Easy access to the platform: dedicated anti-slip step
- > Quick machine with mobile pothole protections
- > Intuitive control box with battery level indicator in platform
- > Smart transportability and lifting
- > Platform extension deck : + 0,4 m

... WITH THE BEST VALUE FOR MONEY

- > Robust machine
- > 4-stage-cylinder mast: no chain, no cable
- > Minimal maintenance & downtime
- > Direct electric drive with maintenance-free AC motors (brushless)
- > Easy access to components (2 swing out trays)
- > Haulotte Activ'Screen (onboard diagnostic)

VERTICAL MASTS

TECHNICAL DATA

STAR 8 S

Working height	8 m
Platform height	6 m
Lift capacity - inside	200 kg (1 pers.)
Platform size	0.77 x 1.38 m
A Length	1.4 m
B Width	0.79 m
C Height - stowed	1.98 m
D Wheelbase	1.06 m
E Ground clearance	6 cm
Drive speed proportional	0.8 - 2.0 / 4.5 km/h
Turning radius - outside	1.7 m
Tyres - non marking	318 x 108
Tilt alarm	1° / 3°
Gradeability	25 %
Driveable at full height up to	6.0 m
Power source	12 V - 105 Ah (C5)
Weight	1150 kg

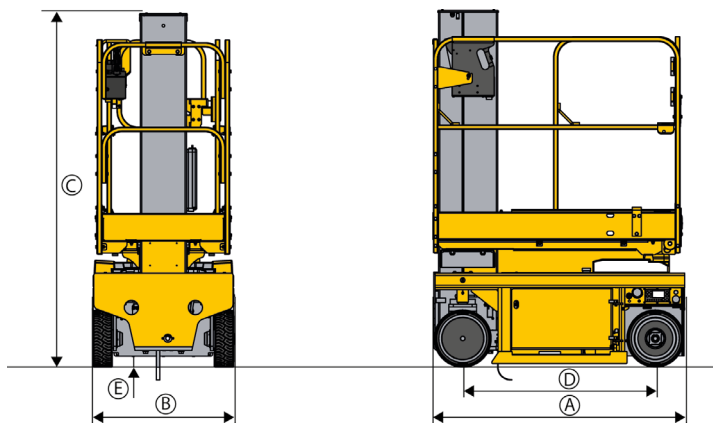

STANDARD EQUIPMENT

- > 24 V electric drive brushless AC motors (free maintenance)
- > 2 x 12V - 105 Ah batteries
- > 20 A battery charger
- > Battery level indicator
- > Haulotte Activ'Screen
- > Fork lifting pockets
- > Hoisting and lifting eyes
- > Door entry gate with lock
- > Platform extension deck: + 0,4 m
- > Mobile pothole protection
- > 2 front steering wheels
- > 2 rear driving wheels
- > Non-marking tires
- > Electric brake release
- > Hourmeter
- > Horn
- > Travel alarm
- > Emergency stop
- > Lowering system
- > 2 control boxes at basket and ground levels
- > Mobile upper control box
- > Drive speed selector on upper control box
- > 2 towing hooks

OPTIONS AND ACCESSORIES

- > Maintenance-free batteries
- > Flashing light
- > Power to platform
- > Tool tray
- > Fluorescent tube caddy
- > Upper control box cover
- > Ground-fault circuit interrupter 30mA
- > Cold weather hydraulic oil
- > Biodegradable hydraulic oil

